

S.D.S. and Accessories

Purified Water Storage and Distribution Systems

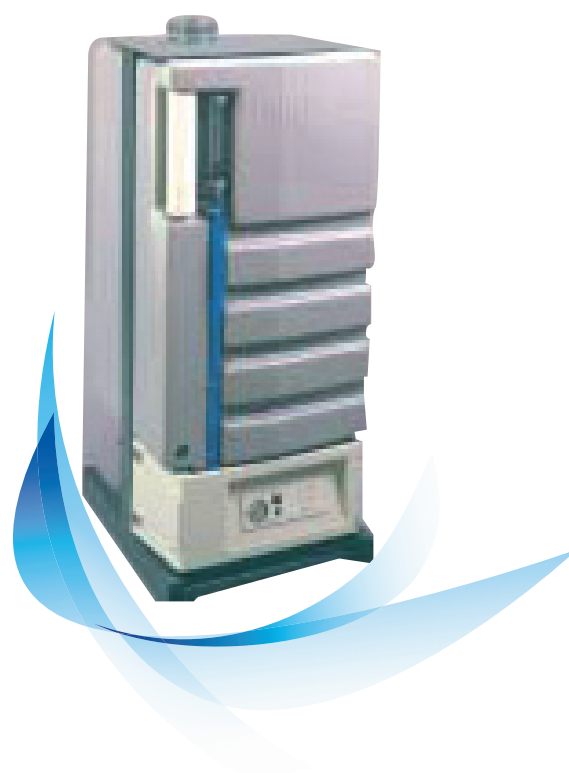

Complete, compact systems for the storage and distribution of purified water

Pure Water Storage and Distribution

Purified water for the laboratory is often produced by reverse osmosis and Merck Millipore's patented Elix® Technology. Merck Millipore's compact S.D.S. Storage and Distribution Systems are designed to store up to 350 liters of purified water, maintain consistent purity of stored water, provide effective protection against airborne contamination, and can distribute the purified water under pressure to multiple-use locations.

Maintaining water purity during storage is critical. Merck Millipore's Automatic Sanitization Module (ASM) prevents bacterial growth and the build-up of biofilm, an accumulation of active and dead bacteria on the inner surface of the storage reservoir.

Merck Millipore Service Support engineers can help to design the total water purification system (including pure water storage) best suited to specific needs, providing detailed specifications and information on all integral parts of the system.

Key Benefits:

- Built-in features to maintain pure water quality
- Programmable operation ensures consistent delivery of pure water to all required points
- Complete control of all storage and distribution functions via the main make-up water purification system
- Qualification program, preventive maintenance plans and full technical support available for peace of mind

Total Water Purification System

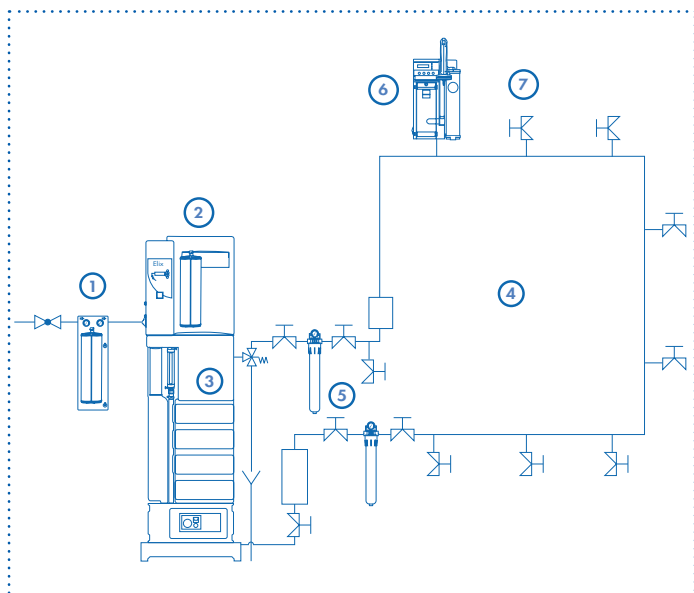

Figure 1: Example of a Total Water Purification System

A total water purification system requires the main water purification system to be integrated into a centralized system. For example:

1. Pretreatment
2. Make-up water purification system (Elix® system)
3. Storage reservoir
4. Distribution loop
5. Accessories (UV lamp, resistivity monitor, bacteria filter, etc.)
6. Milli-Q® system (point-of-use polisher)
7. Pure water point of use

The total water purification system must meet the expected performance levels by ensuring that all components have been designed and implemented according to strict guidelines. Merck Millipore provides this expertise throughout the project.

Purified Water Distribution to Multiple Locations

Pure water in larger volumes is needed for many applications including feed water to Milli-Q® and Super-Q® ultrapure water systems, equipment feed to dishwashers and autoclaves, and for direct use in rinsing and preparation of reagents, buffers and culture media. S.D.S. systems provide optimized storage of 200 to 350 liters of pure water ready for distribution. Built-in pump options can easily distribute water under pressure to multiple locations directly where it is needed.

Elix® and RiOs™ Systems – One Complete Purification and Control Unit

Merck Millipore has developed Elix® and RiOs™ systems for users requiring up to several thousand liters per day of purified water. These systems incorporate all water purification technologies needed to produce the required quality of purified water as well as the complete control functions for the Total Water Purification System.

Elix® and RiOs™ systems provide complete control of the:

- Distribution loop pump
- In-line distribution loop UV lamp
- Automatic Sanitization Module (ASM) on the storage reservoir
- Resistivity and TOC* monitoring of water in the distribution loop
- Distribution loop automatic drain valve
- Water detector
- Additional feed water booster pump if tap feed pressure is too low.

* Elix® systems only



Compact design requires minimal floor space and any Elix® or RiOs™ system can be installed directly on top of the storage reservoir.

Planning a water distribution loop that will meet desired flow rate and pressure needs requires engineering expertise to determine the adequate pump size based on calculated piping and equipment pressure losses. Strict design guidelines must be followed to avoid piping dead-legs and achieve minimum flow velocity through the distribution loop.

Distribution Pump Operation

The built-in stainless steel centrifugal distribution pump was specifically selected for its ability to operate continuously without generating significant temperature or noise level increases. Merck Millipore Elix® and RiOs™ systems provide complete programmable control of the distribution pump. The distribution pump operating mode can be preprogrammed for a seven-day cycle (with specific settings for each day), for intermittent operation (to take into account periods of non-use), or for continuous operation (by manually overriding the automatic settings).

Figure 2: Distribution pump performance

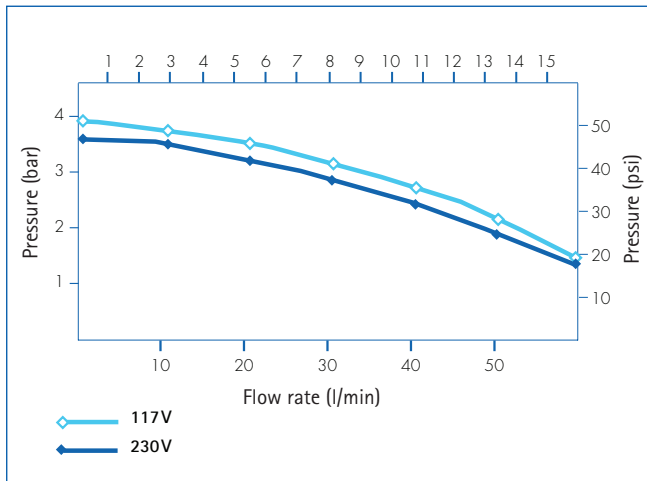

Figure 3: Recirculated water temperature during continuous or intermittent operation

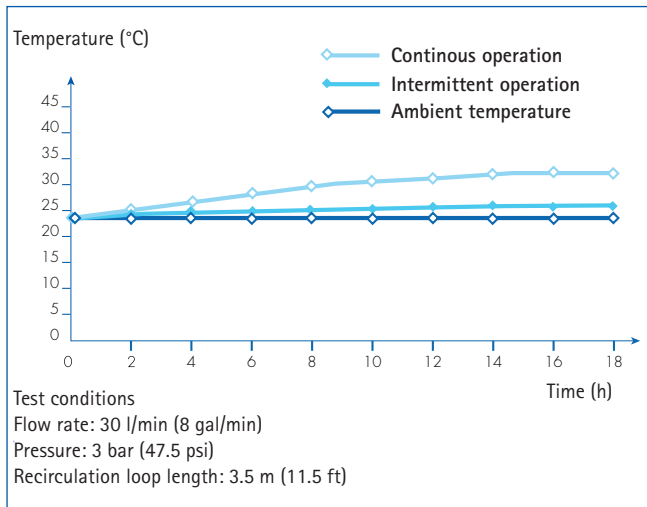

Table 1: Example - Typical distribution pump and distribution loop performance

Distribution loop flow rate	30 liters/min (8 gallons/min)
Distribution loop pressure Pump pressure Minimum loop pressure	3.3 bar (47.5 psi) 2.0 bar (29 psi)
Distribution loop piping Total length External diameter Internal diameter	50 m (160 ft) 25 mm (0.98 in) 20.4 mm (0.80 in) nominal dn-25 (3/4 in)
Piping material	Thermally welded polypropylene
Flow velocity	1.5 m/s (5 ft/s)

Merck Millipore design experts can help determine the correct pump option to meet specific water flow rate, pressure and distribution requirements.

Advanced Protection Against Airborne Contaminants

Carefully designed reservoirs should incorporate advanced vent filtration and sanitary overflow devices as effective mechanisms to prevent the ingress of possible contaminants from the environment. These include carbon dioxide, particles, micro-organisms and volatile organic compounds that mainly come from the laboratory atmosphere. To protect the purified water from these contaminants, Merck Millipore has developed an advanced vent filter incorporating:

- Activated carbon to adsorb volatile organics
- A soda-lime bed to remove carbon dioxide
- An absolute membrane filter for particle and bacteria retention

The advanced vent filter is recommended to protect high resistivity water such as Elix® product water during storage. A standard vent filter using an absolute membrane is available to protect stored reverse osmosis quality water. The vent filter is easily installed in the built-in holder on the front of the S.D.S. reservoir.

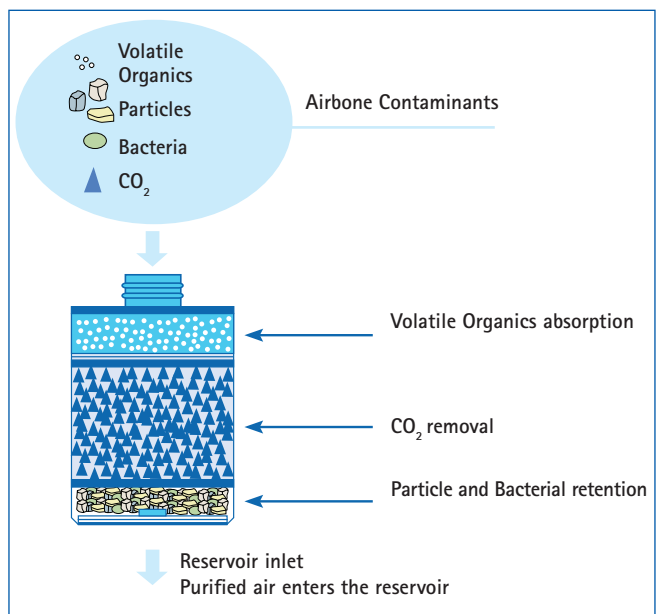

Figure 5: Advanced reservoir vent filter

UV Sanitization A Sound Investment for the Purity of Stored Water

Trace amounts of bacteria, present in purified water, can proliferate and result in the formation of a biofilm on the inner surfaces of the storage reservoir. This biofilm is difficult to remove, even with periodic chemical sanitization and mechanical scrubbing, and is a frequent source of recontamination in stored water. Merck Millipore's Automatic Sanitization Module (ASM) prevents bacterial proliferation and the resulting biofilm formation on the inner surface of S.D.S. reservoirs.

The ASM Module incorporates the following features to guarantee optimum performance:

- Ultraviolet (UV) light at 254 nm, generated by a low pressure mercury vapor lamp, selected for its germicidal effectiveness
- Compact design, allowing easy installation in the top of S.D.S. reservoirs
- Total control directly from Merck Millipore Elix® or RiOs™ systems for maximum effectiveness and ease-of-use, including:
 - pre-programmed, 10-minute daily automatic UV illumination
 - additional programmable and manual UV illumination cycles to meet critical application requirements
 - up to 60 minutes UV exposure per day for total flexibility
 - UV lamp exchange alarm for optimum performance and easy maintenance
 - recovery of all operating parameters in case of a power failure.

Optimized Pure Water Storage and Distribution

The main concern when storing and distributing purified water is the degradation of water quality over time. Strict choices in the storage reservoir material, reservoir design and appropriate protection against airborne contaminants will ensure consistent water quality during storage.

Figure 5: Germicidal effectiveness of the UV lamp

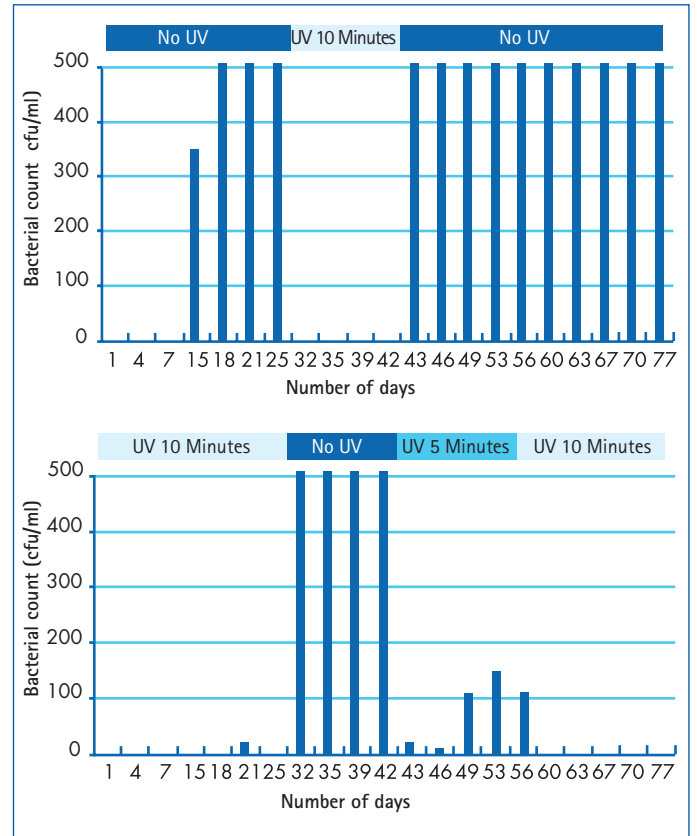

Unique Design Features Ensure Consistent Water Quality

Merck Millipore S.D.S. 200- and 350-liter systems incorporate the most advanced technological developments and innovative features to guarantee consistent purity of stored and distributed water.

1. Polyethylene reservoir ensures minimal release of organics and smooth inner surface prevents biofilm formation.
2. Conical bottom guarantees no dead volume and allows complete cleaning, draining and rinsing.
3. ASM Automatic Sanitization Module UV lamp easily added to minimize bacterial growth during storage.
4. Sanitary overflow prevents the ingress of contaminants from the drain.
5. Choice of vent filters to protect stored water against airborne contamination.
6. Sensor rod float switch for automatic reservoir refill.
7. Built-in pump options can distribute purified water to multiple locations.
8. Inlet and outlet connections and valves are all preplumbed for easy installation.

Figure 6: Direct display of stored water volume and level on Elix® or RiOs™ systems.

The diagram shows a reservoir with a conical bottom. Component 1 is the reservoir body. Component 2 is the conical bottom. Component 3 is the ASM UV lamp. Component 4 is the sanitary overflow. Component 5 is the vent filter. Component 6 is the sensor rod float switch. Component 7 is the built-in pump. Component 8 is the inlet and outlet connections and valves.

Specifications

S.D.S. Specifications

Characteristic	S.D.S. 200	S.D.S. 350
Water Volume	200 Liter (53 gal)	350 Liter (92 gal)
Weight (filled with water)	250 kg (550 lbs)	390 kg (860 lbs)
Dimensions H x W x D	1020 x 600 x 700 mm (40 x 24 x 27.5 in)	1420 x 600 x 700 mm 56 x 24 x 27.5 in)
Floor space required	0.42 m ² (4.5 ft ²)	0.42 m ² (4.5 ft ²)
Pump performance (for systems with standard pump)	30 liters/min at 3 bar pressure (8 gal/min at 45 psi). Pump operation is controlled by Elix [®] or RiOs [™] water systems	

Merck Millipore Application Specialist will optimize pump to meet specific requirements.

ASM Specifications

Total length:	320 mm (12.6 in)
Length of lamp quartz housing:	215 mm (8.5 in)
Length of cable for direct connection to Elix [®] or RiOs [™] system	5 m (16.4 ft)
Install and UV lamp replacement requirement	250 mm (9.8 in) above SDS tank

ASM operation is controlled and powered directly from Elix[®] or RiOs[™] water system.

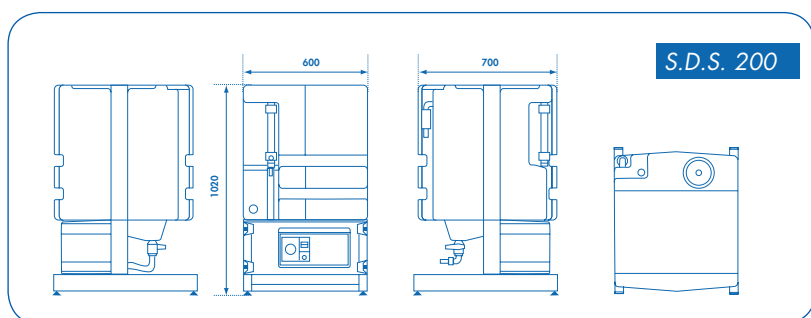

Electrical Specifications*

- 117 V/60 Hz (10 A Slo-Blo[®] fuse)
- 230 V/50 Hz (5 A Slo-Blo fuse)
- Relay output rating: 3 pole dry contact, 240 VAC max, 50/60 Hz, 2200 VA

* standard pump version

Materials:

Reservoir	Polyethylene
Frame	Epoxy painted passivated steel
Valves and fittings	Polypropylene
Tubing	Polyethylene
Pump wetted parts	316 SST and tungsten carbide/ carbon and EPDM seals
Pressure gauge	316 SST

Drain Capacity

200 l/h at max height of 200 mm above floor

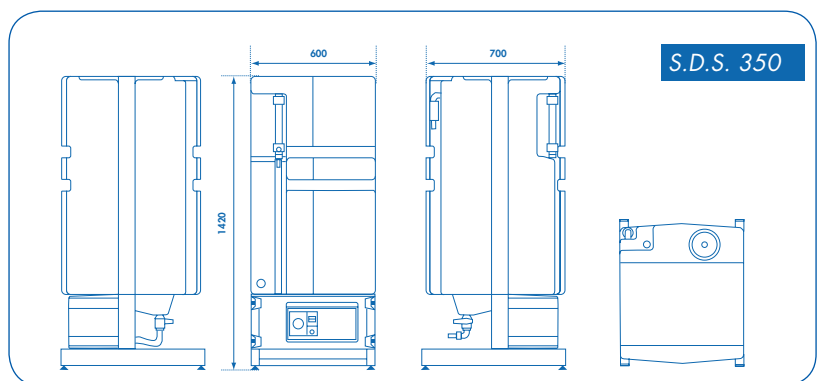

Level Sensor Specifications

5 m (16.4 ft) cable for direct connection to RiOs[™] or Elix[®] system

Plumbing Connections

Pure Water inlet to reservoir	8 mm female quick connect
Reservoir Drain and main outlet	20 mm hose barb fitting
Reservoir loop return inlet	3/4-in NPT
Vent filter	Standard 12-in code-O O-ring
Overflow connection	20 mm tubing

(2 3/4 in ball valves and 5 m of 20 mm tubing with fittings are included)



Lit. No. PF050EN00. 01/2012.

© 2012 EMD Millipore. Millipore, Elix, Super-Q and Milli-Q are registered trademarks of Merck KGaA, Darmstadt, Germany.

M mark, Merck Millipore and RiOs are trademarks of Merck KGaA. Slo-Blo is a registered trademark of Littlefuse Inc.

Photos: Bernard Minier and Henry Thurel – BHL Productions. Layout: Infoflash/Québec – RCS Evry B353 615 065.