

Millipore®

User Guide

Series 4000™ Filter Housings

Contents

Operator and Equipment Safety	5
Introduction.....	5
Maximum Operating Conditions	5
Housing Installation	6
Exploded View	6
Cartridge Installation	7
Sterilization	7
Steam-in-place.....	7
Autoclaving.....	8
Cartridge Wetting and Integrity Testing	8
Filtration	9
Liquid Filtration.....	9
Gas filtration	9
Maintenance	9
Cleaning Stainless Steel parts.....	9
Cleaning or Changing Seals.....	10
Storage.....	10
Accessories & Spare parts.....	11

Operator and Equipment Safety

Refer to the Series 4000™ Filter Housing Operator and Equipment Safety Guide, document number 20415020 for this information.

Introduction

Series 4000™ housings are shipped with the housing, base, clamp and seal. Filter cartridges, pressure gauges and other accessories must be ordered separately.

Series 4000™ housings are supplied with a Certificate of Quality that provides product traceability for Quality Assurance.

Unpacking, installation and operation of the housing must be performed by qualified operators.

Maximum Operating Conditions

Temperature	Pressure range
25°C (77°F)	-1 to 10 bar
	-14.5 to 145 psi
	-100 to 970 kPa
60°C (140°F)	-1 to 7 bar
	-14.5 to 100 psi
	-100 to 700 kPa
80°C (176°F)	-1 to 6 bar
	-14.5 to 87 psi
	-100 to 600 kPa
145°C (293°F)	-1 to 3.2 bar
	-14.5 to 46 psi
	-100 to 320 kPa

Housing Installation

- Install the filter housing in a location with sufficient clearance for cartridge installation and removal.
- The inlet and outlet connections on this housing provide adequate support for the housing and its full liquid weight.
- Any ancillary equipment connected to this housing should be qualified to prevent excessive load to the inlet and outlet fitting.
- Pressure gauges or sensors should be installed to monitor the filtration system pressure.
- Sterilization requires full steam penetration onto all internal surfaces. Ensure that the filter housing position enables complete elimination of air through the vent as well as complete elimination of condensate through the drain.

Exploded View

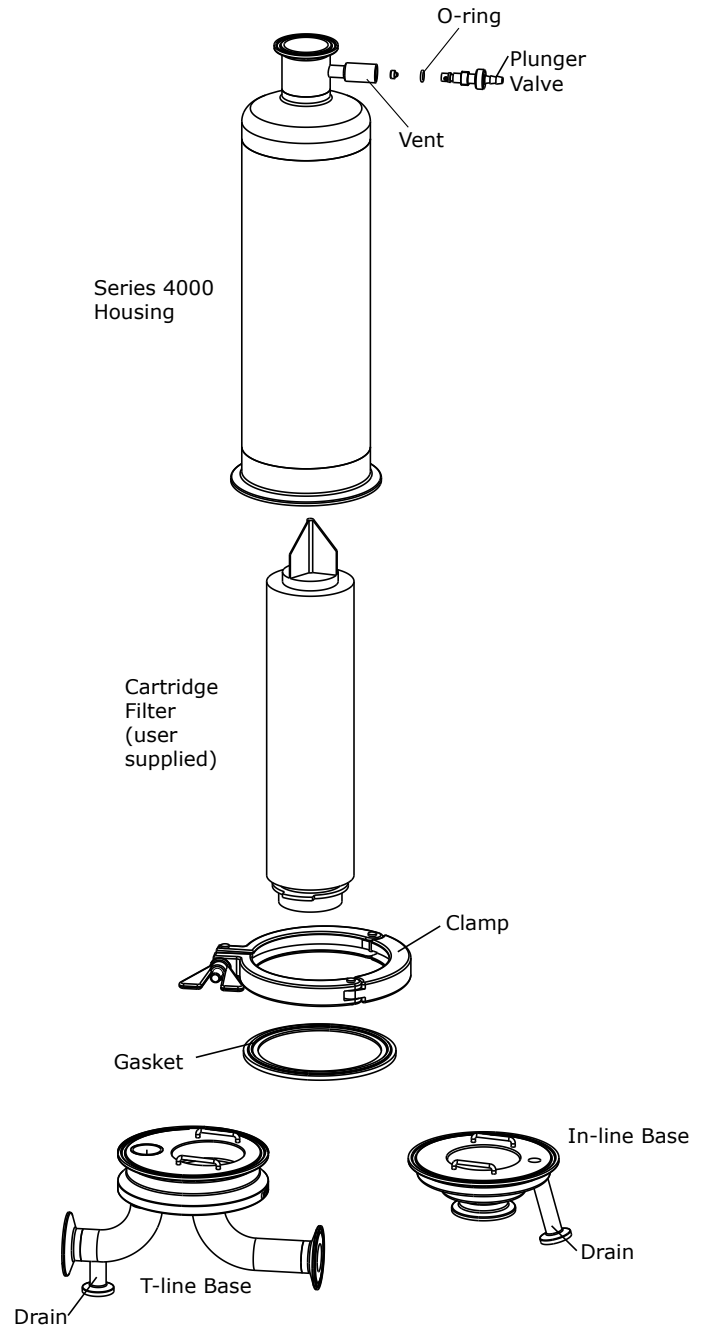

Cartridge Installation

1. Open the clamp and remove it from the housing.
2. Ensure that the interior of the housing is clean and free of particles.
3. Remove the cartridge filter from the plastic bag.
4. Wet the O-ring with purified water to ease cartridge installation.
5. Insert the cartridge bottom into the housing base by twisting the cartridge slightly while exerting downward pressure until the adapter tabs properly engage in the locking area.

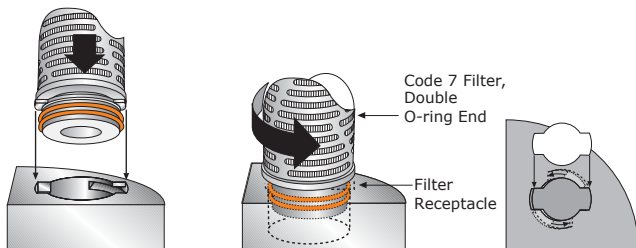
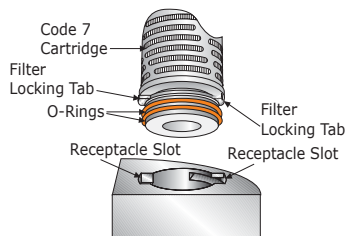

Cartridge installation

6. Place the housing onto the base, ensuring the gasket is seated properly in the base groove.
7. Secure the closure with the sanitary clamp.
8. Hand tighten the clamp (do not overtighten).

Sterilization

Steam-in-place

NOTES Steam in place sterilization cycles must be validated by the user.

Steam supply must be saturated and free from condensation and particles.

Steam traps should be used to allow proper condensate removal during steaming.

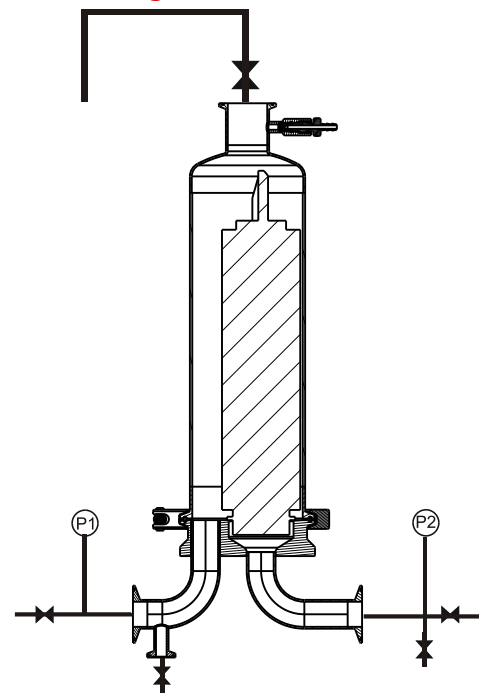

Steam-in-place schematic

1. Close the inlet valve and connect the steam line to the inlet valve
2. Check that the steam pressure is properly set.
3. Open the housing or system vent valve.
4. Open the housing drain valve (if installed).
5. Close the outlet valve.
6. Open the outlet drain valve.
7. Gradually open the inlet valve.
8. Ensure that the inlet pressure is less than 0.3 bar (5 psi).
9. Gradually open the inlet valve to increase the steam pressure.
10. Gradually open the outlet valve.

NOTE The differential pressure (inlet pressure versus outlet pressure) must be within the cartridge specifications.

11. Once the inlet and outlet pressure gauges show the desired pressure, the sterilization cycle begins.
12. When sterilization time is complete, close housing vent and drain valves. Shut off the steam valve and simultaneously introduce compressed air or nitrogen gas to allow cooling and positive pressure inside the filter housing.
13. Once the filter assembly is cooled down, maintain positive pressure to prevent external contamination by closing outlet and inlet valves. Release the gas pressure before use.

Autoclaving

1. Wrap the housing inlet and outlet connections with appropriate barrier paper or phobic filter.
2. Loosen the vent and drain valves and wrap them with barrier paper.

NOTE Do not use aluminium foil to cover openings.

3. Place the filter assembly in the autoclave. Position the assembly to properly remove air and drain condensate. The use of a support to maintain the vertical position of the filter assembly may be necessary.

NOTE Any tubing attached to the filter housing needs to be positioned to ensure complete condensate drainage.

4. Proceed with the autoclaving.
5. After cooling, hand tighten vent and drain valves.
6. Install the filter assembly on the process system using aseptic techniques.

NOTE Autoclave cycles must be validated to ensure filter assembly sterilization. Do not exceed the maximum temperature limit and time exposition of the membrane filter.

Cartridge Wetting and Integrity Testing

Refer to the wetting guide delivered with the cartridge for wetting instructions.

Perform a filter integrity test prior to use, after sterilization. Refer to the wetting guide delivered with the cartridge for more information.

Filtration

Liquid Filtration

1. Connect the process feed to the filter inlet.
2. Open the inlet valve.
3. Vent the filter housing by opening the high point vent valve.
4. When the fluid starts flowing from the vent valve, close the vent valve.
5. Set up the operating conditions (flow rate, pressure).
6. Vent the housing until liquid flows from the high point vent valve

NOTE Do not exceed the maximum specification limits of the cartridge filter and filter housing.

Before opening the filter housing, the pressure must be released and product drained by opening the vent or drain valve slowly.

Gas filtration

NOTE To operate the filtration system for air and gas filtration, monitor the pressure at the inlet and the outlet to allow control of the differential pressure through the membrane.

1. Close vent and drain valves. Open the inlet and the outlet valves.
2. Adjust the pressure supply to provide the desired flow rate.

NOTE Do not exceed the maximum specification limits of the cartridge filter and filter housing.

3. Condensed moisture can accumulate on the cartridges. Such blockage is indicated by a progressive rise in differential pressure or drop in flow rate. In this case, drain off condensate at the upstream side. Please consider using a heating jacket in this case and an appropriate drainage mechanism.

Maintenance

Series 4000™ filter housings are designed and manufactured to assure that materials and construction methods bring trouble-free service over long periods, when the equipment receives proper care. AISI 316L/1.4404 Stainless Steel is used. Elastomers used for sealing O-rings and gaskets are selected to meet special requirements for chemical compatibility and sanitary use.

Use a preventive maintenance schedule for replacing O-rings and gaskets. At a minimum, periodically inspect all O-ring and gasket seals as part of the cleaning and maintenance procedure.

Cleaning Stainless Steel parts

Fittings, welded parts, surfaces and housing design have been specifically developed and qualified to enable easy and effective cleaning-in-place (CIP) and steaming-in-place (SIP).

Cleaning out of place can also be performed with a washing machine or manually. Use a nonabrasive cleaner and a soft cloth or brush. Avoid harsh abrasives, steel wool, or scouring pads, since they can result in damage to the sanitary finish by pitting the steel and allowing corrosion to begin, or by creating a non-sanitary surface.

1. Dismantle the housing to access all parts.
2. Clean the stainless steel housing with an appropriate nonabrasive or liquid cleaner.
3. After cleaning, rinse thoroughly with tap water, followed by a purified water rinse to prevent water spots.
4. When air drying housings, carefully position the housings to prevent water pooling.

Cleaning or Changing Seals

Cleaning or replacing the O-ring and the gasket requires complete disassembly of the housing.

1. Slowly open the housing vents and drains to relieve pressure in the housing before disassembly.
2. Unscrew the vent valve located at the top of the housing and the drain valve located in the base to access the vent and drain valve O-ring and the plug seal.
3. Remove the dome from the housing base.
4. Remove all O-rings and seals when the housing is fully disassembled.
5. Visually inspect all O-rings and seals for cracks or splits.

NOTE The life expectancy of these seals varies depending on process fluid, temperature, and pressure.

6. Replace any seal with apparent damage.

Storage

Dry all components completely before storage. If the equipment is to be stored for long periods without use, components should be stored separately, in a clean area with good air circulation. Do not allow stored components to be in contact with each other, or in contact with surfaces that can absorb moisture from the atmosphere (such a cloth or paper sheets).

NOTE Permanently damp surfaces will tarnish the stainless steel and eventually start to cause corrosion.

Accessories & Spare parts

For a complete listing of accessories and spare parts, please refer to product datasheet or contact technical support.

Description	Qty per Pack	Catalog Number	Recommended	Optional
Gaskets Kits				
½ in. TC gasket, Silicone	10	HGTC050SP	√	
½ in. TC gasket, EPDM	10	HGTC050EP	√	
½ in. TC gasket, PTFE encapsulated fluoroelastomer	10	HGTC050T0	√	
1 in. TC gasket, Silicone	10	HGTC100SP	√	
1 in. TC gasket, EPDM	10	HGTC100EP	√	
1 in. TC gasket, PTFE encapsulated fluoroelastomer	10	HGTC100T0	√	
1 ½ in. TC gasket, Silicone	10	HGTC150SP	√	
1 ½ in. TC gasket, EPDM	10	HGTC150EP	√	
1 ½ in. TC gasket, PTFE encapsulated fluoroelastomer	10	HGTC150T0	√	
4 in. TC gasket, Silicone	10	HGTC400SP	√	
4 in. TC gasket, EPDM	10	HGTC400EP	√	
4 in. TC gasket, PTFE encapsulated fluoroelastomer	10	HGTC400T0	√	
Vent Valve Seal Kits				
Seal kit, Silicone o-ring and PTFE tip	10	HGPVS0KIT	√	
Seal kit, EPDM o-ring and PTFE tip	10	HGPVEPKIT	√	
Seal kit, fluoroelastomer o-ring and PTFE tip	10	HGPVV0KIT	√	
Tri-clamps				
TC ¾ in.(= TC ½ in.)	2	HCLMP0075IN2		√
TC 1 in. ½ (= TC 1 in.)	2	HCLMP0150IN2		√
TC 4 in. (3 pieces clamp)	1	P34303		√
TC 4 in. (2 piece bolted clamp to be used with PTFE encapsulated gasket)	1	P35015		√
Accessories				
Plunger valve stem (made of 316 L)	2	H1PVSTEM2		√
316 L Cap, ½ in. TC or ¾ in. TC	2	HPLG00075IN2		√
316 L Cap, 1 in. TC or 1 ½ in. TC	2	HPLG00150IN2		√
Pressure gauge, psi + bar type (0-160 psi, 0-11 bar)	1	P90001		√
Pressure gauge, Kpa + bar type [0-1,100 Kpa, 0-11 bar]	1	P90005		√
Code 7 to code 0 adaptor kit	1	HGADAPT0RC7/0		√

We provide information and advice to our customers on application technologies and regulatory matters to the best of our knowledge and ability, but without obligation or liability. Existing laws and regulations are to be observed in all cases by our customers. This also applies in respect to any rights of third parties. Our information and advice do not relieve our customers of their own responsibility for checking the suitability of our products for the envisaged purpose.

For technical assistance
please visit:

www.emdmillipore.com/techservice.
Worldwide contact information is available at
www.emdmillipore.com/offices

For additional information and
documentation please contact:

Merck KGaA, Darmstadt, Germany
Corporation with General Partners
Frankfurter Str. 250
64293 Darmstadt, Germany
Phone: + 49 6151-72 0

For requests from USA and Canada
please contact:

MilliporeSigma Corporation,
A subsidiary of Merck KGaA, Darmstadt,
Germany
400 Summit Drive
Burlington, MA 01803 USA
Phone: 1-800-645-5476

Millipore and Series 4000 are trademarks of Merck KGaA, Darmstadt, Germany or its affiliates. All other trademarks are the property of their respective owners. Detailed information on trademarks is available via publicly accessible resources. © 2019 Merck KGaA, Darmstadt, Germany and/or its affiliates. All Rights Reserved.

MK_UG4852EN Rev. 1 10/2019

The Merck logo is displayed in a bold, blue, sans-serif font. The letters are thick and closely spaced, with a distinctive shape for the 'M' and 'R'.